

ITEM NO.	PART NUMBER	DESCRIPTION	QTY.
1	002.00.00140	LOCK WASHER INOX Ø4	6
2	002.00.00095	INOX NUT M4	6
3	003.00.00309	INOX TAPPING SCREW Ø4,1 X 13	4
4	001.15.00082	LOWER BACK COVER 1500	1
5	001.15.00001	BACK COVER 1500	1
6	003.15.00119	CONTROL PANEL COMPLETE A1510	1
7	001.00.00213	INOX SCREW M4X15	2
8	001.00.00247	M6X25 SCREW DIN6115	2
9	001.15.00156	FRONT COVER A1510	1

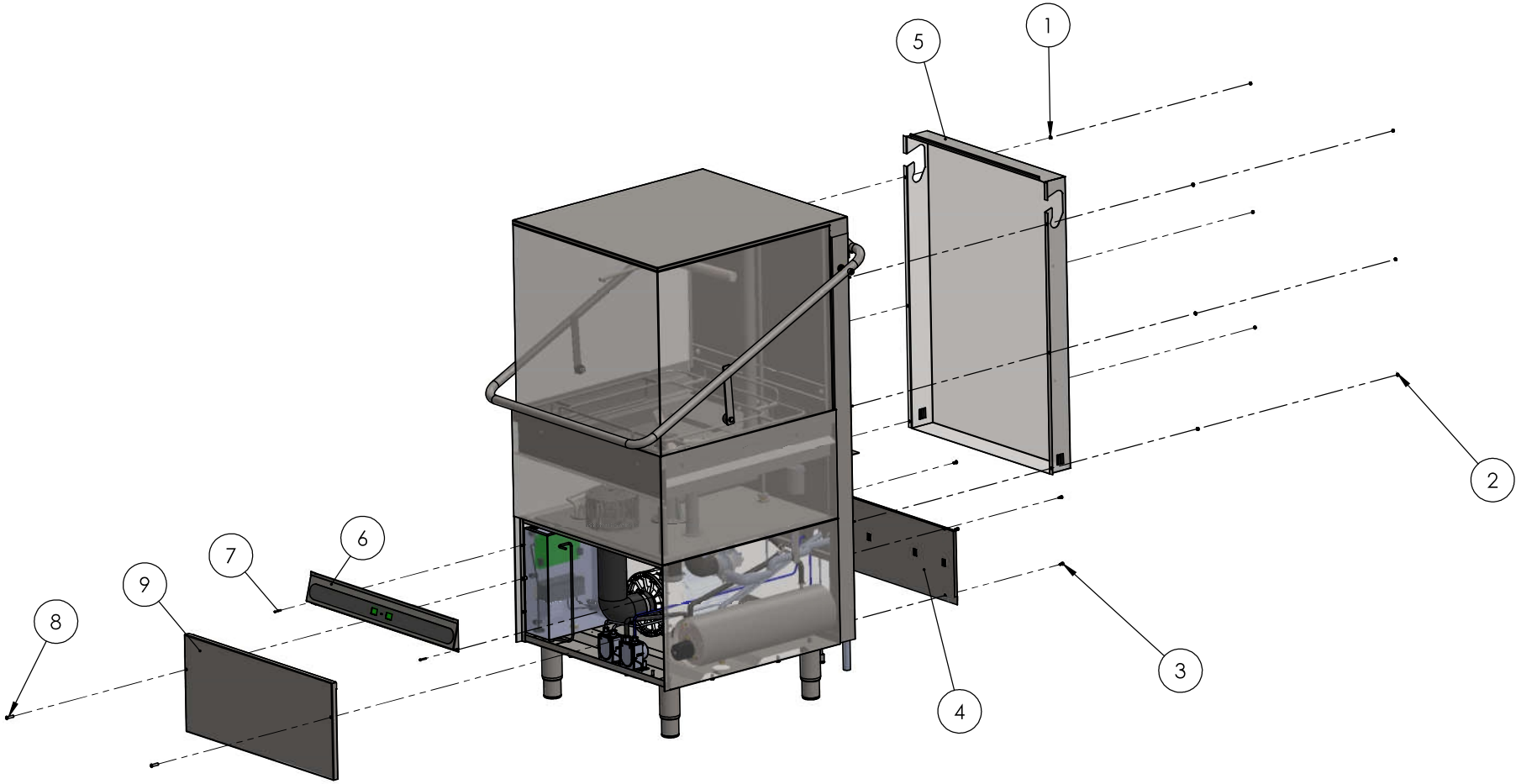

**SERIES DESCRIPTION:**  
DISHWASHER

**MODEL DESCRIPTION:**  
1510

**MODEL VERSION:**  
380V-415V 3~N 50/60 Hz

**MODEL CODE:**  
004.15.00027

**PAGE:**  
01

**REVISION:**  
01

ITEM NO.	PART NUMBER	DESCRIPTION	QTY.
10	002.15.00044	PLASTIC GUIDE D.30	4
11	003.00.00346	TAPPING SCREW 4,8X13	12
12	001.15.00150	UPPER COVER	1
13	002.15.00074	TEFLON WASHER $\Phi 16 \times \Phi 8 \times 1$	2
14	003.00.00221	INOX WASHER $\Phi 6 \times \Phi 18$	2
15	003.00.00323	COPLER $\Phi 8 \times \Phi 31$	2
16	002.15.00053	INOX AXLE BOLT M8X35 LONG	2
17	003.00.00274	INOX BOLT M10 X 64 ALLEN	2
18	001.15.00029	DOOR HANDLE 1500	1
19	001.00.00093	M10 NUT INOX	2
20	002.00.00095	INOX NUT M4	4
21	002.00.00274	TEFLON 10X4X1	4
22	002.00.00117	INOX MUT M8	2
23	002.15.00052	INOX AXLE BOLT SHORT M8 X 17	2

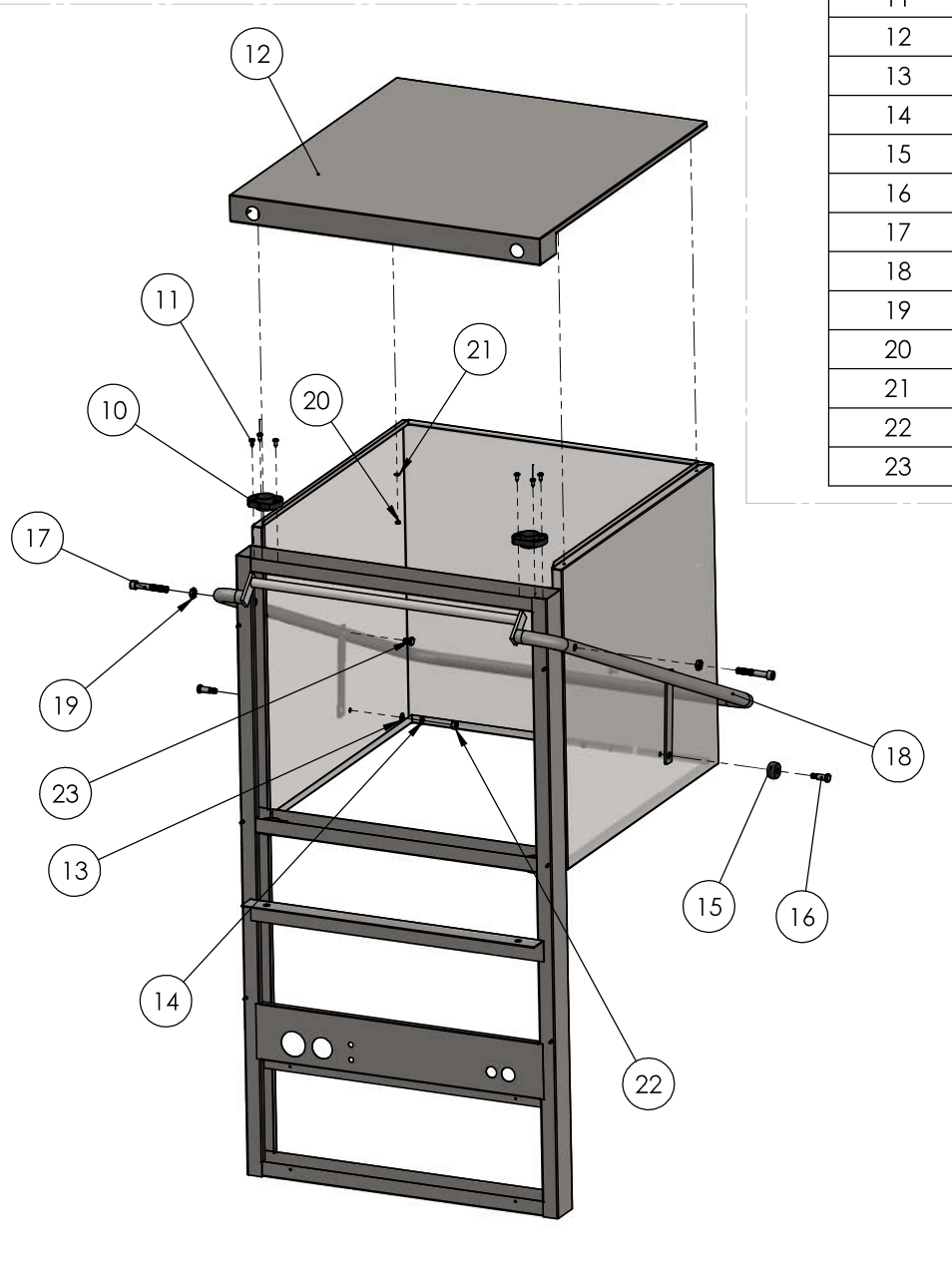

**SERIES DESCRIPTION:**  
DISHWASHER

**MODEL DESCRIPTION:**  
1510

**MODEL VERSION:**  
380V-415V 3~N 50/60 Hz

**MODEL CODE:**  
004.15.00027

**PAGE:**  
02

**REVISION:**  
01

ITEM NO.	PART NUMBER	DESCRIPTION	QTY.
24	001.15.00084	HOOD SUPPORT PIPE $\Phi 30 \times 1100$	2
25	001.15.00145-1	INOX HOOD SPACER $\Phi 12 \times 24$	2
26	001.15.00036	INOX BOLT M8 X 70	2
27	002.15.00074	TEFLON WASHER $\Phi 16 \times \Phi 8 \times 1$	2
28	003.00.00221	INOX WASHER $\Phi 6 \times \Phi 18$	2
29	001.15.00037	DOOR SPRING TURBO 1500	2
30	002.00.00117	INOX MUT M8	2
31	002.00.00207	TAPPING SCREW 4,2 X 19	1
32	002.00.00233	DETERGENT TANK INJECTOR	1
33	003.00.00033	PRESSOSTAT	1
34	003.00.00025	CABLE RUBBER PROTECTOR	2
35	003.00.00140_11	TUBO TRASPARENTE 4x6	1
36	003.00.00487-7	TUBO PVC BLUE 4x6	1
37	002.00.00242	FILTER PLASTIC FOR RINSE AID VALVE	2
38	002.00.00195	BALANCE F15X20	2
39	002.00.00264	ELBOW DRAINING PIPE OD29-ID19	1
40	002.00.00109	INLET HOSE 1500mm	1

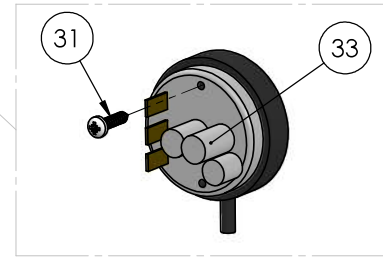
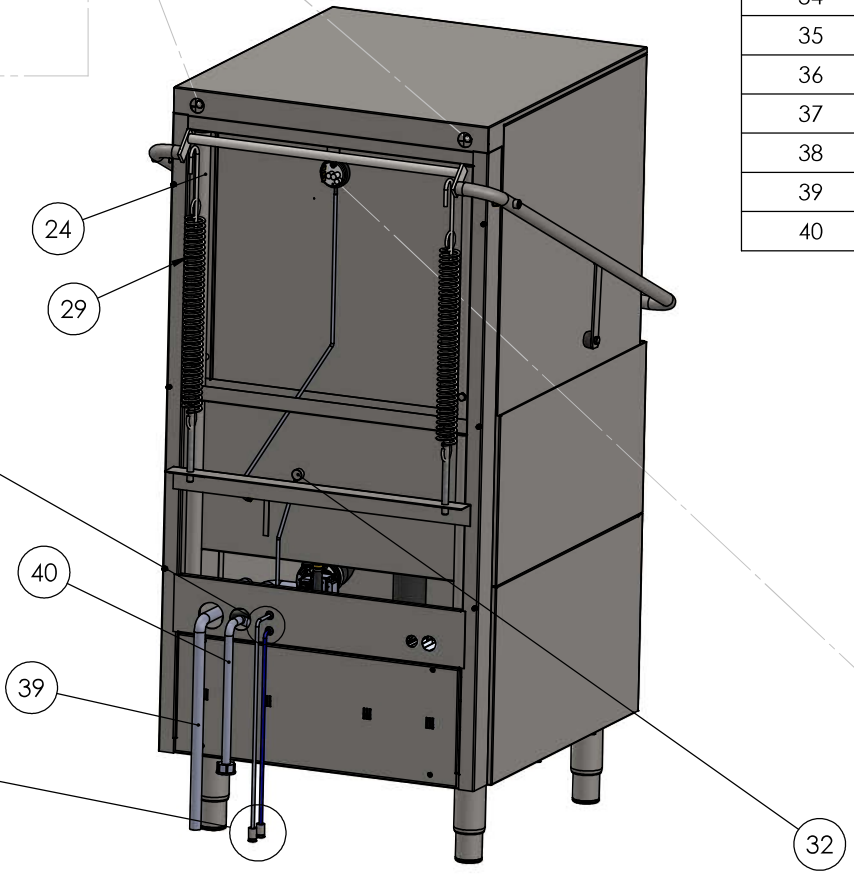
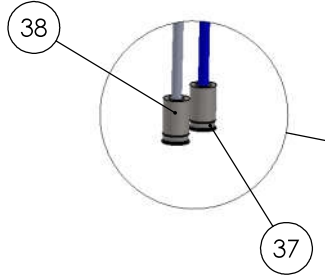
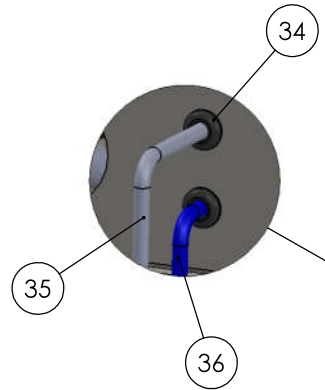
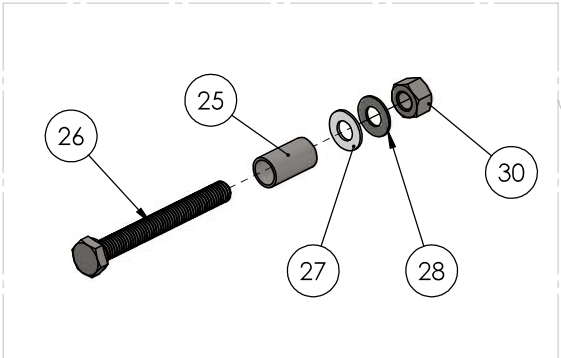

<b>SERIES DESCRIPTION:</b> DISHWASHER	<b>MODEL DESCRIPTION:</b> 1510	<b>MODEL VERSION:</b> 380V-415V 3~N 50/60 Hz	<b>MODEL CODE:</b> 004.15.00027	<b>PAGE:</b> 03	<b>REVISION:</b> 01
--	-----------------------------------	---	------------------------------------	--------------------	------------------------

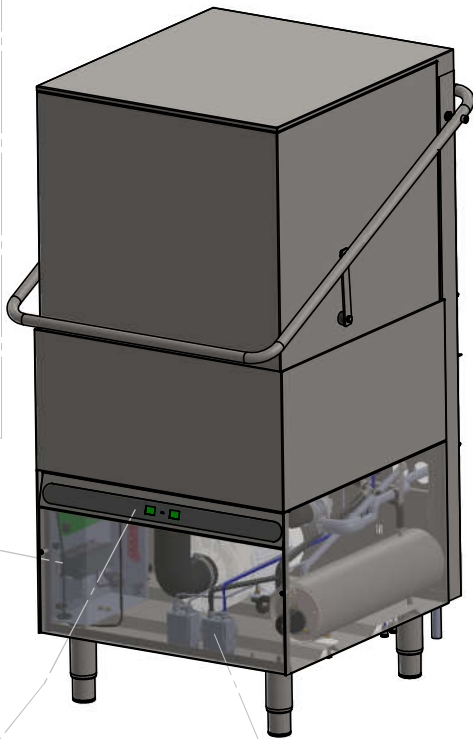
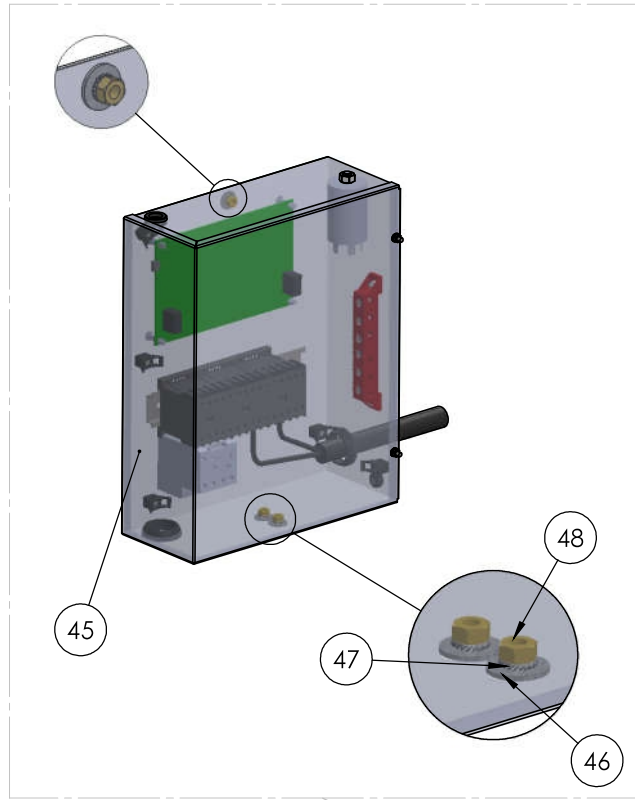

ITEM NO.	PART NUMBER	DESCRIPTION	QTY.
41	002.00.00140	LOCK WASHER INOX Φ4	2
42	002.00.00095	INOX NUT M4	2
43	003.00.00684	PERISTALTIC DETERGENT PUMP SEKO 3lt FIXED FLOW	1
44	003.00.00687	PERISTALTIC RINSE-AID PUMP SEKO 0,7lt FIXED FLOW	1
45	006.15.00009	ELECTRICAL BOX COMPLETE	1
46	003.00.00516	WASHER STEEL Φ6X18	3
47	001.00.00204	GALVANIZED LOCK WASHER 6,4x11x0,7	3
48	003.00.00041	NUT M6 GALVANISED	3
49	003.15.00119	CONTROL PANEL COMPLETE A1510	1

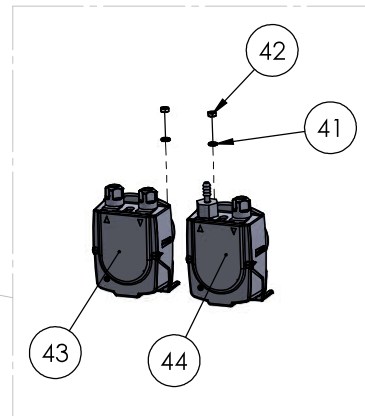
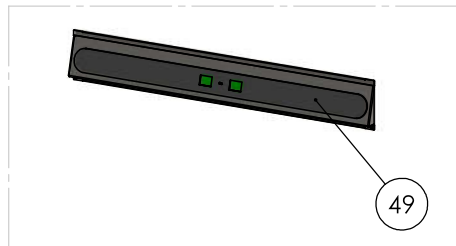

**SERIES DESCRIPTION:**  
DISHWASHER

**MODEL DESCRIPTION:**  
1510

**MODEL VERSION:**  
380V-415V 3~N 50/60 Hz

**MODEL CODE:**  
004.15.00027

**PAGE:**  
04

**REVISION:**  
01

ITEM NO.	PART NUMBER	DESCRIPTION	QTY.
50	001.15.00155	DISPLAY PANEL INOX A1510	1
51	003.00.00609	USER INTERFACE 7 SEGM. DISPLAY VERSION	1
52	002.00.00090	GALV. NUT M3	4
53	003.15.00117	FILM FOR A1510 (LCD)	1
54	003.00.00629	ATLAS-USER CONNECTION CABLE L=1000mm	1

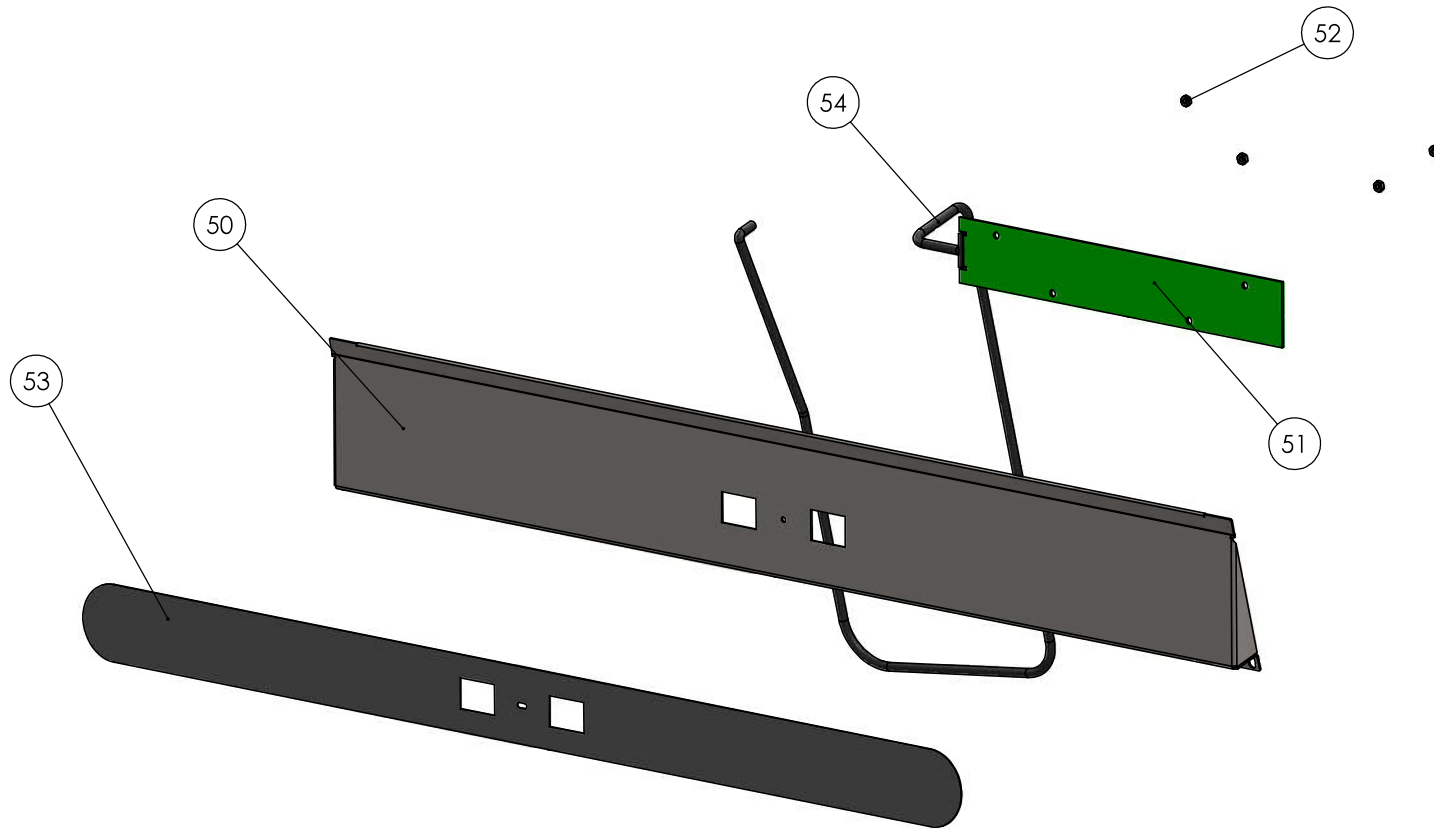

**ITEM CODE:**  
003.15.00119

**ITEM DESCRIPTION:**  
CONTROL PANEL COMPLETE  
A1510

**SERIES DESCRIPTION:**  
DISHWASHER

**MODEL DESCRIPTION:**  
1510

**MODEL VERSION:**  
380V-415V 3~N 50/60 Hz

**MODEL CODE:**  
004.15.00027

**PAGE:**  
05

**REVISION:**  
01

ITEM NO.	PART NUMBER	DESCRIPTION	QTY.
55	001.15.00101-1	ELECTRICAL COMPONENTS PANEL 1500	1
56	003.00.00056	MAGNETIC CONTACTOR	3
57	003.00.00607	ATLAS MAIN BOARD VERSION	1
58	003.00.00630	SPACER PCB RC-12 PLASTIC	4
59	003.15.00010	THERMAL OVERLOAD RELAY 2,5 - 4,0	1
60	003.00.00030	POWER SUPPLY BOARD 6CON	1
61	003.00.00625	ELECTROMAGNETIC FILTER 250V 50/60Hz 10A 40oC	1
62	003.00.00025	CABLE RUBBER PROTECTOR	1
63	003.00.00347	RUBBER CABLE PROTECTION N.01	1
64	003.00.00466	PIPE RUBBER PROTECTOR	2
65	003.00.00494	CABLE PLASTIC CLAMP	5
66	001.15.00102-1	ELECTRICAL COMPONENTS BOX COVER 1500	1
67	003.00.00301	NUT M8 GALV	1
68	003.00.00046	NUT M4 (GALV)	4
69	002.00.00140	LOCK WASHER INOX Ø4	2
70	003.15.00118	MAIN WIRING SET A 1510 NED	1

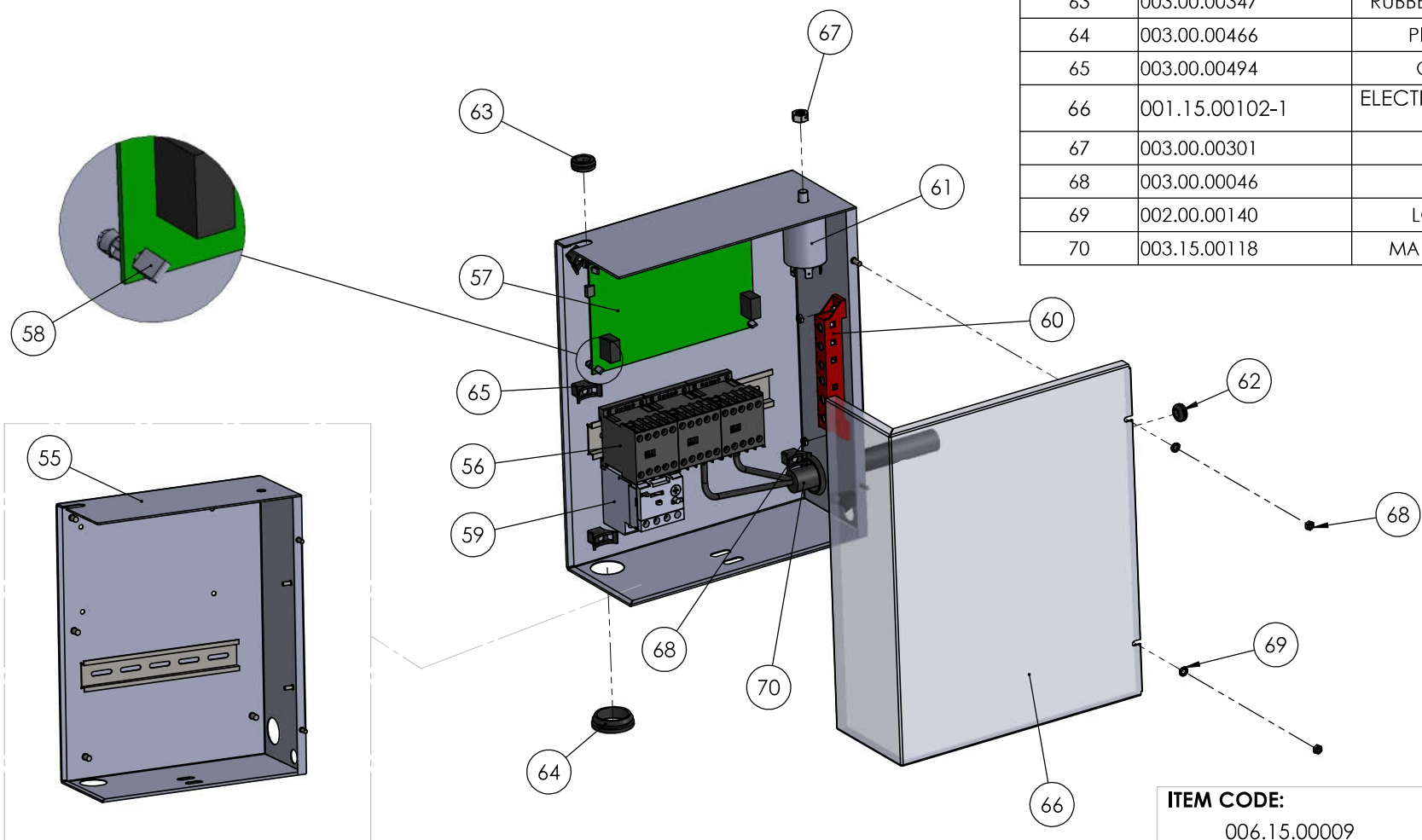

**ITEM CODE:**  
006.15.00009

**ITEM DESCRIPTION:**  
ELECTRICAL BOX COMPLETE

**SERIES DESCRIPTION:**  
DISHWASHER

**MODEL DESCRIPTION:**  
1510

**MODEL VERSION:**  
380V-415V 3~N 50/60 Hz

**MODEL CODE:**  
004.15.00027

**PAGE:**  
06

**REVISION:**  
01

ITEM NO.	PART NUMBER	DESCRIPTION	QTY.
71	003.00.00516	WASHER STEEL $\Phi 6 \times 18$	6
72	001.00.00204	GALVANIZED LOCK WASHER 6,4x11x0,7	6
73	003.00.00041	NUT M6 GALVANISED	6
74	003.00.00063	PUMP 1,50Hp, 400V, 50Hz	1
75	002.15.00058	PUMP INLET HOSE	1
76	003.00.00323-B	COPLER $\Phi 8 - \Phi 31$	4
77	002.00.00051	CLAMP 60-80	2
78	002.00.00051-1	CLAMP 60-80	2
79	002.15.00029	PUMP OUTPUT HOSE	1
80	006.15.00008	BOILER 1500 400V COMPLETE (1 HEATING ELEMENTS)	1

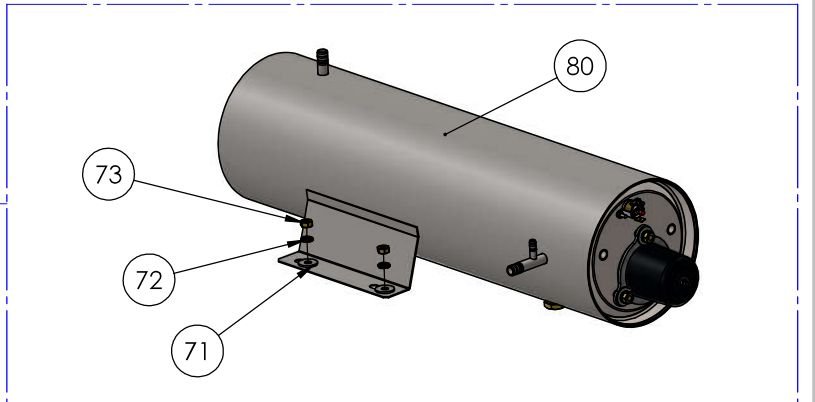
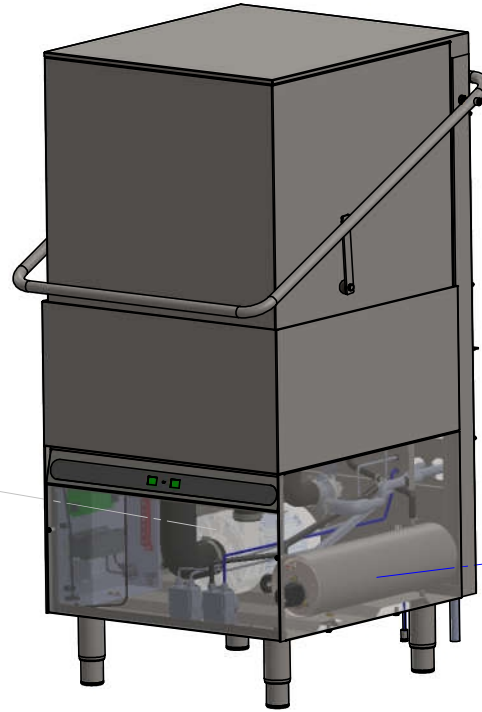
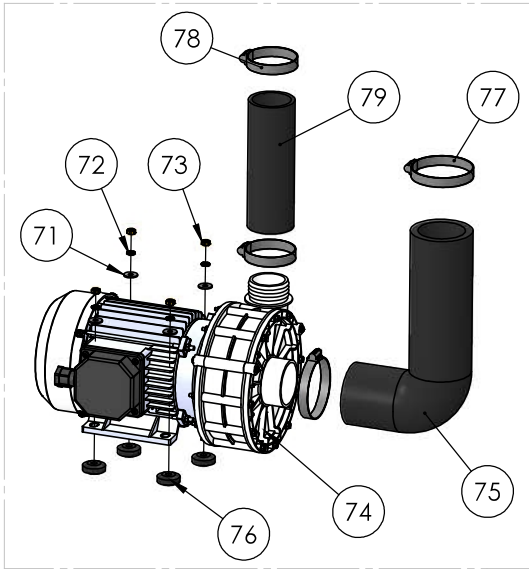

**SERIES DESCRIPTION:**  
DISHWASHER

**MODEL DESCRIPTION:**  
1510

**MODEL VERSION:**  
380V-415V 3~N 50/60 Hz

**MODEL CODE:**  
004.15.00027

**PAGE:**  
07

**REVISION:**  
01

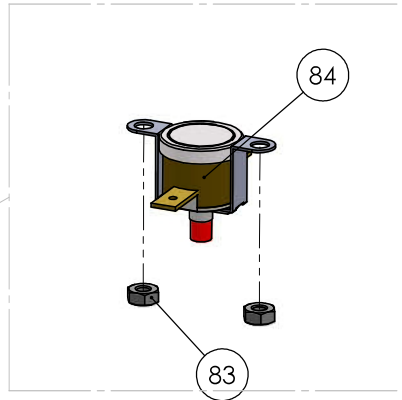

ITEM NO.	PART NUMBER	DESCRIPTION	QTY.
81	002.00.00140	LOCK WASHER INOX Ø4	2
82	002.00.00095	INOX NUT M4	2
83	002.00.00090	GALV. NUT M3	2
84	003.00.00168	THERMOFUSE TANK 90C	1
85	001.15.00169	BRACKET FOR DRAINING PUMP A1510	1
86	003.00.00184_595	TANK DRAINING PUMP 230V / 65W	1
87	002.00.00127-1	WASH PUMP HOSE (INPUT)	1
88	003.00.00355	INOX HEX SCREW M6X12	2
89	002.00.00049	CLAMP 35-50	2
90	002.00.00264	ELBOW DRAINING PIPE OD29-ID19	1
91	003.00.00244	CLAMP 20-32	1
92	001.00.00256	LEVELING FEET 1 3/4	4

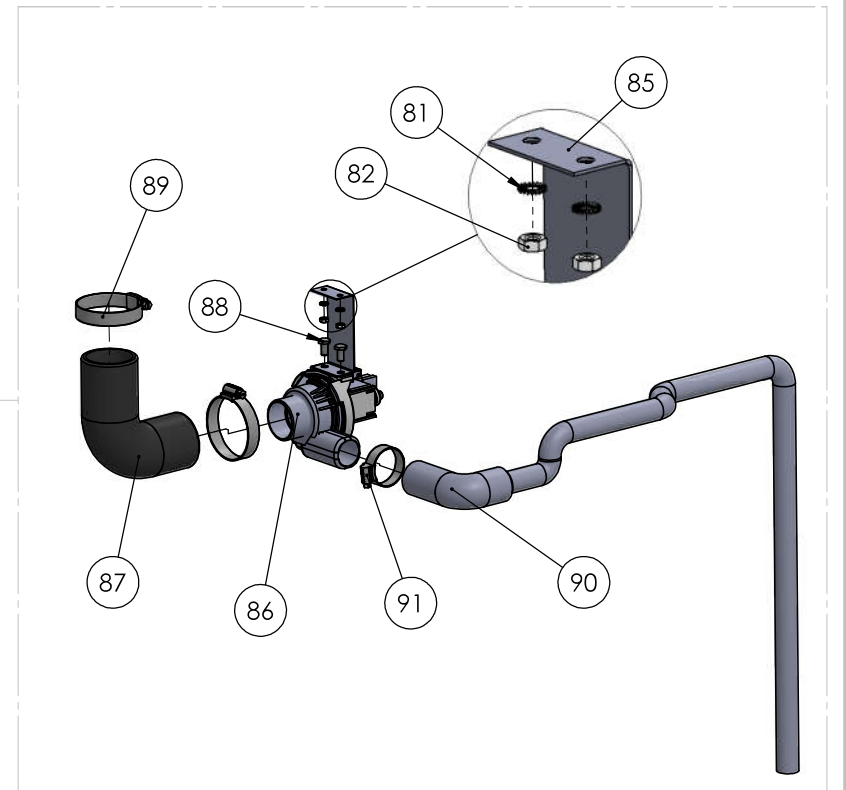

**SERIES DESCRIPTION:**  
DISHWASHER

**MODEL DESCRIPTION:**  
1510

**MODEL VERSION:**  
380V-415V 3~N 50/60 Hz

**MODEL CODE:**  
004.15.00027

**PAGE:**  
08

**REVISION:**  
01



ITEM NO.	PART NUMBER	DESCRIPTION	QTY.
93	003.00.00278	GALV. BOLT M4X10	2
94	003.00.00046	NUT M4 (GALV)	2
95	003.15.00003	DOOR SWITCH 1500	1
96	003.00.00151	Water Input Valve Double	1

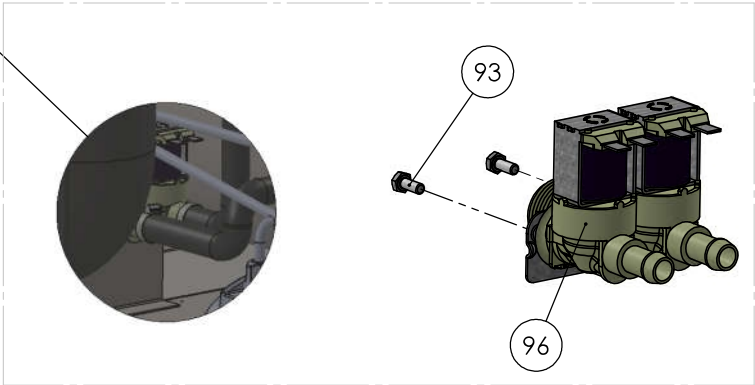
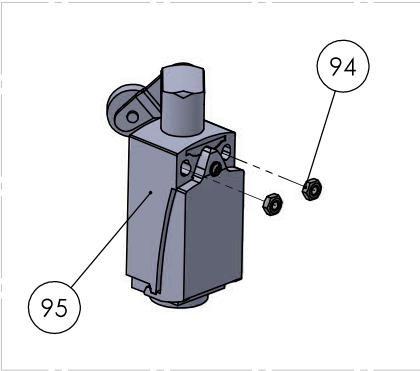
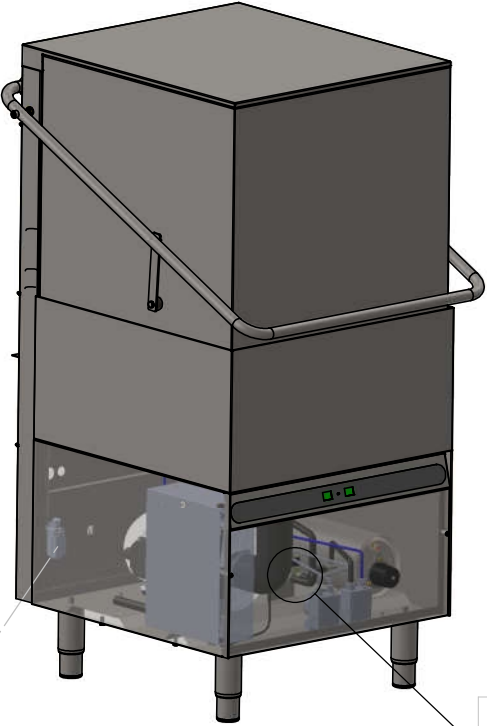

**SERIES DESCRIPTION:**  
DISHWASHER

**MODEL DESCRIPTION:**  
1510

**MODEL VERSION:**  
380V-415V 3~N 50/60 Hz

**MODEL CODE:**  
004.15.00027

**PAGE:**  
09

**REVISION:**  
01

ITEM NO.	PART NUMBER	DESCRIPTION	QTY.
97	001.15.00148	BOILER TURBO 1500 NEW	1
98	003.00.00575	HEATER ELEMENT BOILER 1500, 7,5kW NEW	1
99	003.00.00260	BOILER ELEMENT FITTING BASE	1
100	003.00.00180	BOILER THERMOFUSE 105oC	1
101	002.00.00090	GALV. NUT M3	2
102	002.00.00076	BOILER DRAIN THREADED CAP	1
103	003.00.00516	WASHER STEEL $\Phi 6 \times 18$	3
104	001.00.00204	GALVANIZED LOCK WASHER 6,4x11x0,7	3
105	003.00.00041	NUT M6 GALVANISED	3
106	003.00.00004	HEATER ELEMENT COVER	1

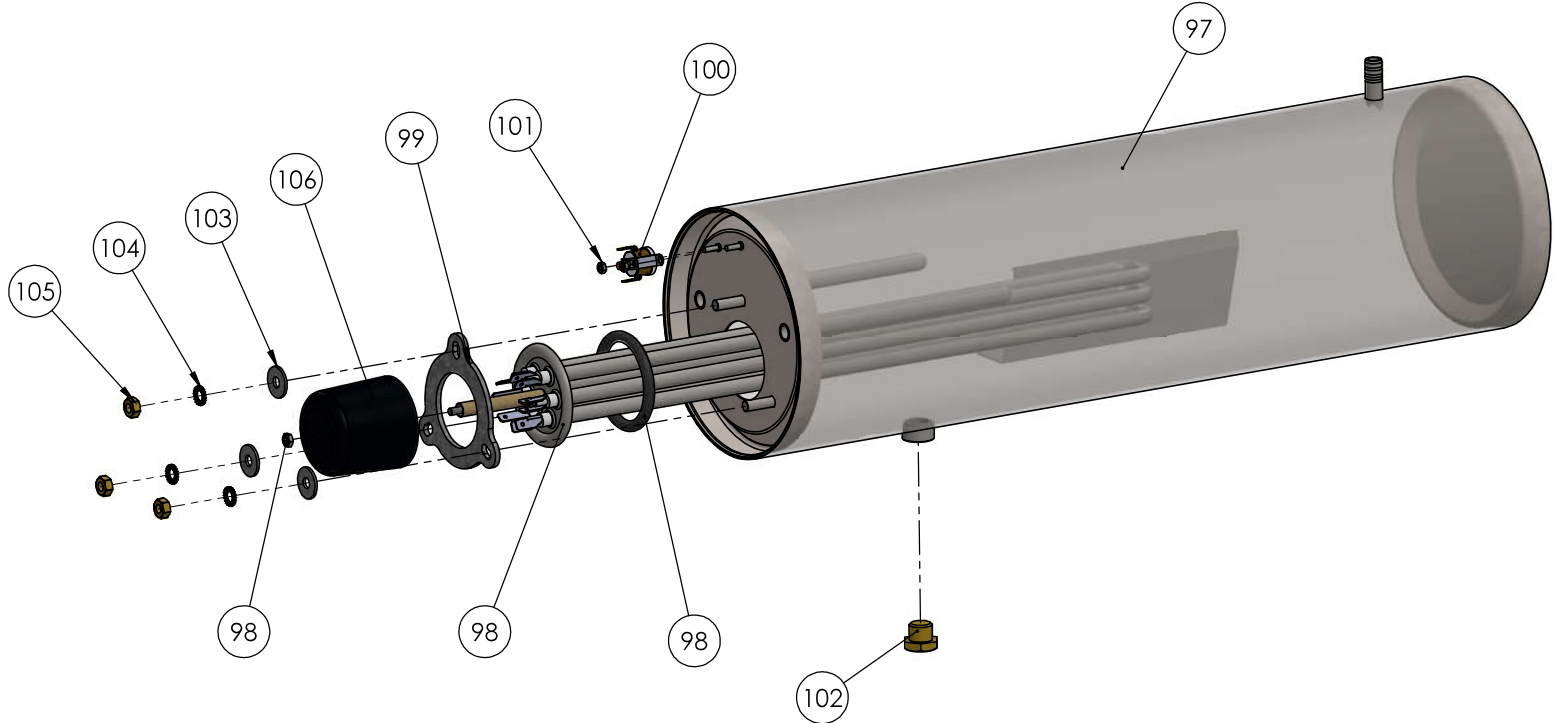

**SERIES DESCRIPTION:**  
DISHWASHER

**MODEL DESCRIPTION:**  
1510

**MODEL VERSION:**  
380V-415V 3~N 50/60 Hz

**ITEM CODE:**  
006.15.00008

**MODEL CODE:**  
004.15.00027

**ITEM DESCRIPTION:**  
BOILER 1500 400V COMPLETE  
(1 HEATING ELEMENTS)

**PAGE:**  
10

**REVISION:**  
01

ITEM NO.	PART NUMBER	DESCRIPTION	QTY.
107	003.00.00441	INOX HEX BOLT M4 X 60	2
108	002.00.00140	LOCK WASHER INOX Ø4	2
109	002.00.00095	INOX NUT M4	2
110	002.00.00207	TAPPING SCREW 4,2 X 19	1
111	002.00.00030	NIPPLE 1/2 INOX	1
112	002.00.00083	RINSE BASE TUR - KN	1
113	002.00.00097	O-RING 20X4	1
114	002.15.00090	RINSE SUPPLY INOX TURBO 1500	1
115	002.00.00144	RINSE PIPE RETAINING NUT	3
116	002.00.00062	NUT 1/2	1
117	001.00.00110	DOMED CAP NUT M6	4
118	002.00.00091	ORING 3X10,5	3
119	002.15.00080	WASH SUPPLY INOX TURBO 1500	1

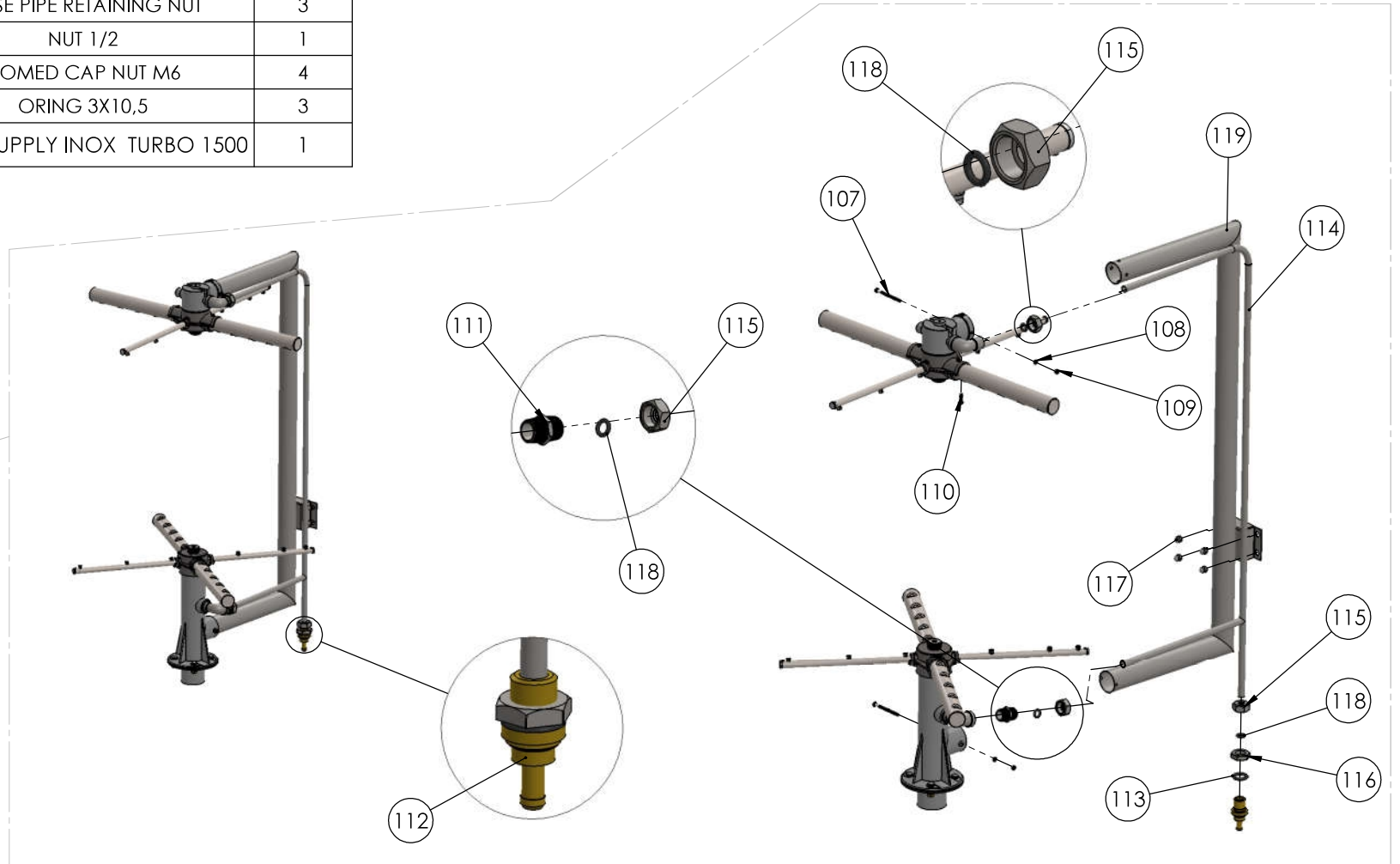

**SERIES DESCRIPTION:**  
DISHWASHER

**MODEL DESCRIPTION:**  
1510

**MODEL VERSION:**  
380V-415V 3~N 50/60 Hz

**MODEL CODE:**  
004.15.00027

**PAGE:**  
11

**REVISION:**  
01

ITEM NO.	PART NUMBER	DESCRIPTION	QTY.
120	002.15.00086	WASH - RINSE UPPER BASE TURBO 1500	1
121	002.15.00082	INOX AXLE $\Phi$ 20 M8 TURBO 1500 EVO	1
122	002.15.00091	WASH AND RINSE CROSS TURBO COMPLETE	1
123	002.15.00083	INOX RETAINING NUT $\Phi$ 25 X 7 M8	1
124	002.00.00226	INCH ANGLE MALE - FEMALE 1/2	1

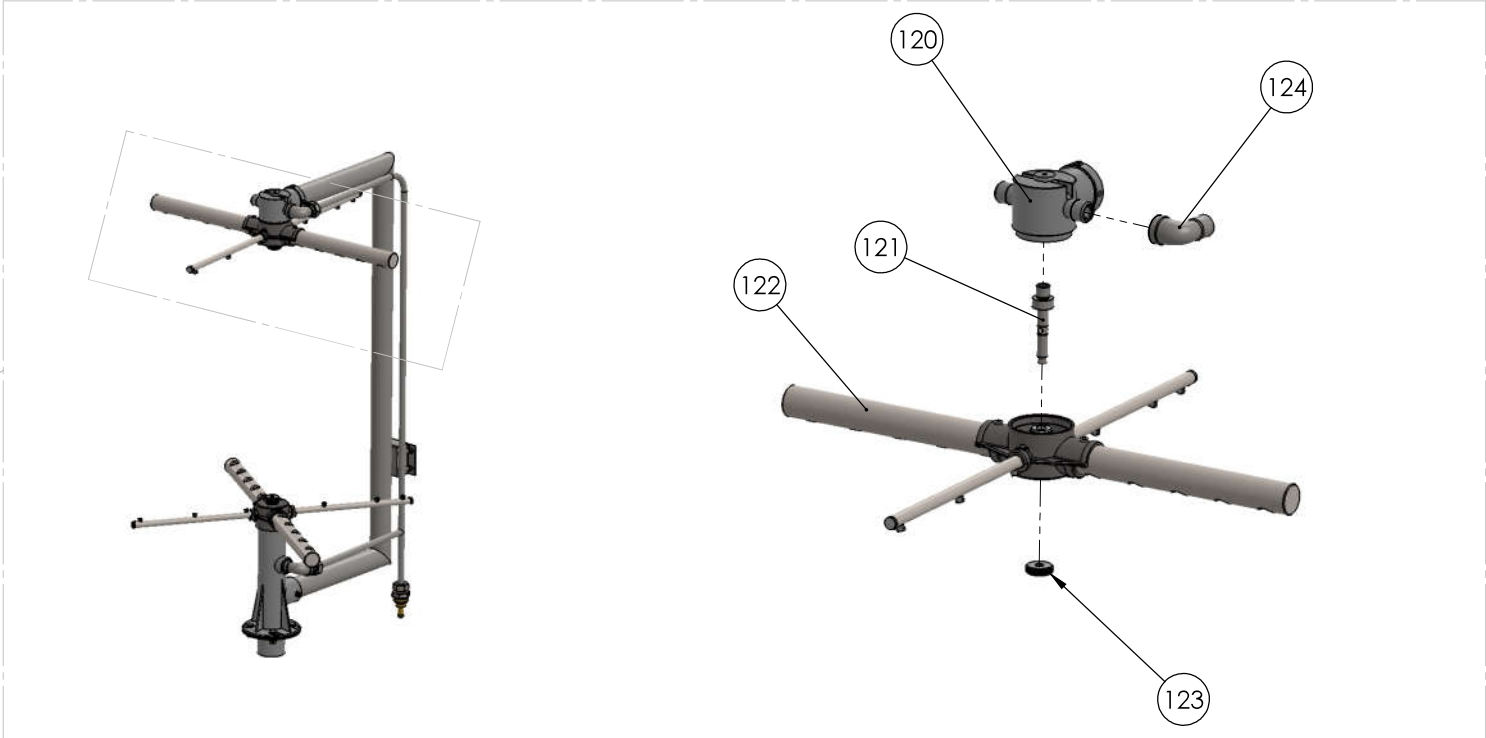

**SERIES DESCRIPTION:**  
DISHWASHER

**MODEL DESCRIPTION:**  
1510

**MODEL VERSION:**  
380V-415V 3~N 50/60 Hz

**MODEL CODE:**  
004.15.00027

**PAGE:**  
12

**REVISION:**  
01

ITEM NO.	PART NUMBER	DESCRIPTION	QTY.
125	002.00.00223	RUBBER GASKET $\Phi 109 \times 54 \times 3$	1
126	002.15.00084-1	WASH & RINSE BASE TURBO 1500	1
127	002.00.00169	TEFLON 12-6-2	4
128	003.00.00104	INOX HEX BOLT M6X20	4
129	003.00.00516	WASHER STEEL $\Phi 6 \times 18$	4
130	001.00.00204	GALVANIZED LOCK WASHER 6,4x11x0,7	4
131	003.00.00041	NUT M6 GALVANISED	4
132	002.15.00103	FLOW CONTROL DISK TURBO 1500	1
133	002.15.00082	INOX AXLE $\Phi 20$ M8 TURBO 1500 EVO	1
134	002.15.00091	WASH AND RINSE CROSS TURBO COMPLETE	1
135	002.15.00083	INOX RETAINING NUT $\Phi 25 \times 7$ M8	1
136	002.00.00226	INCH ANGLE MALE - FEMALE 1/2	1
137	002.15.00024	RETAINING PLATE FOR BASE 1500	1

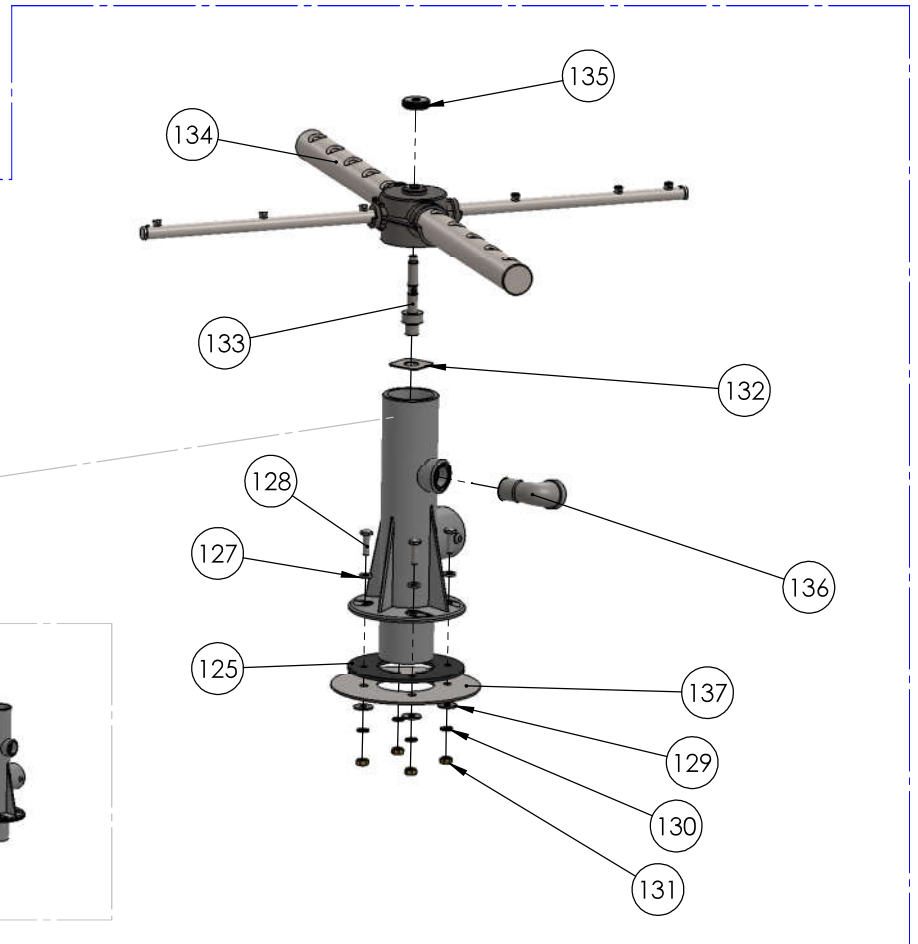

**SERIES DESCRIPTION:**  
DISHWASHER

**MODEL DESCRIPTION:**  
1510

**MODEL VERSION:**  
380V-415V 3~N 50/60 Hz

**MODEL CODE:**  
004.15.00027

**PAGE:**  
13

**REVISION:**  
01

ITEM NO.	PART NUMBER	DESCRIPTION	QTY.
138	002.15.00085	RINSING - WASHING CROSS TURBO 1500	1
139	002.15.00089	PIPES TURBO 1500 INOX $\Phi$ 30 X 1 X 248	2
140	002.15.00093-B	INOX RINSE PIPE TURBO 1500 $\Phi$ 12 X 245	1
141	002.15.00093-A	INOX RINSE PIPE TURBO 1500 $\Phi$ 12 X 245	1
142	002.35.00026	TEFLON $\Phi$ 18 X 10	2
143	002.11.00008	SPRAYER FOR RINSING ARM BL,EU,VE,KN,1500	6
144	002.00.00145	CAP FOR RINSE ARM VE-KN-1500	2
145	003.00.00377	INOX MACHINE SCREW 3,5 X 13	2
146	003.00.00579	INOX SCREW M4 X 10	2
147	003.00.00580	INOX MACHINE SCREW M4 X 10	2
148	001.00.00073	INOX SCREW 2,9 X 10	2

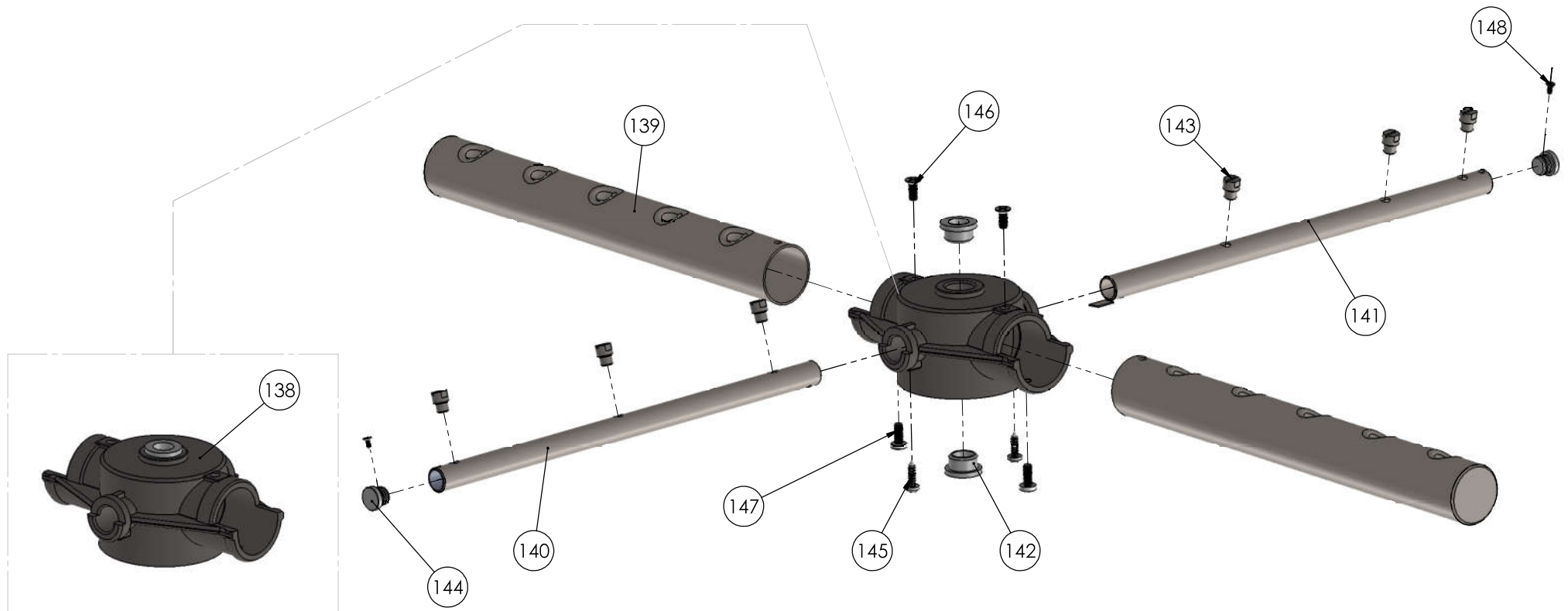

**SERIES DESCRIPTION:**  
DISHWASHER

**MODEL DESCRIPTION:**  
1510

**MODEL VERSION:**  
380V-415V 3~N 50/60 Hz

**MODEL CODE:**  
004.15.00027

**PAGE:**  
14

**REVISION:**  
01

ITEM NO.	PART NUMBER	DESCRIPTION	QTY.
149	001.15.00095	SUPPORT FOR FILTER BACK	1
150	001.15.00012	FILTER ELEMENT	4
151	001.15.00153	Inox Knob For Square Tank Filter 1500-600	1
152	003.00.00242	INOX HEX SCROU M6X12	1
153	001.00.00110	DOMED CAP NUT M6	6
154	001.15.00113	BASKET SUPPORT 1500	1
155	001.15.00094	SUPPORT FOR FILTER MID	1

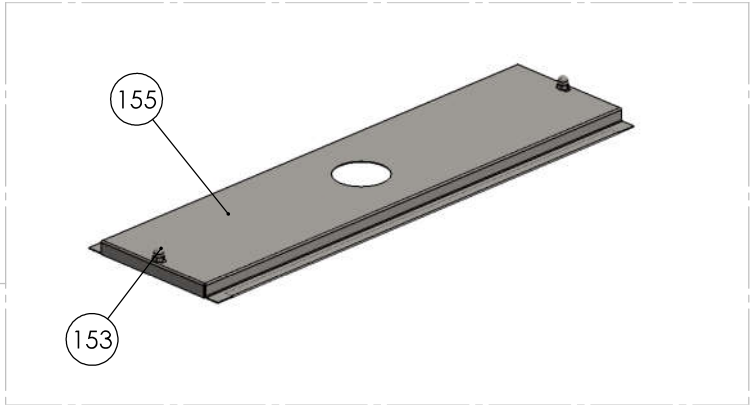
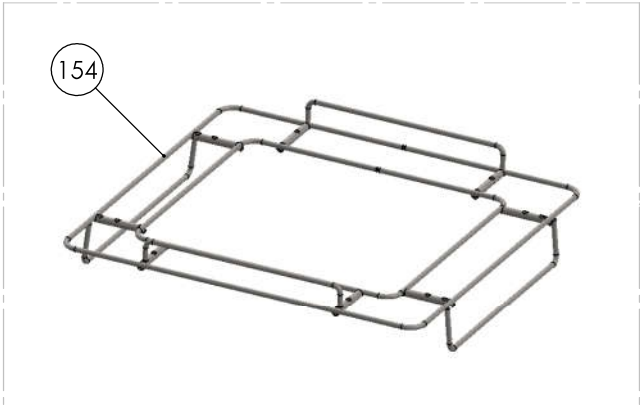
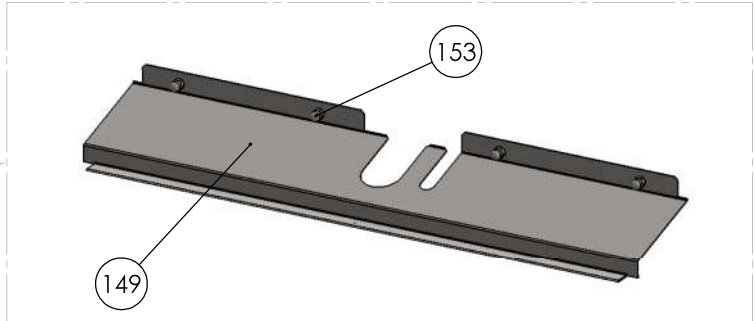
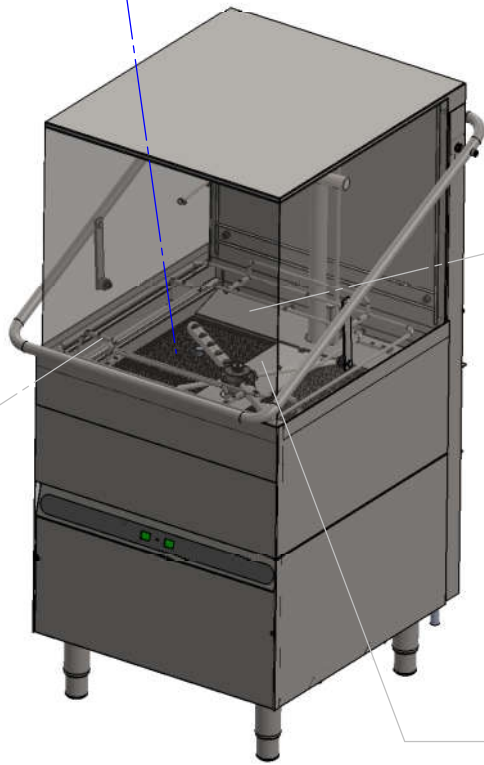
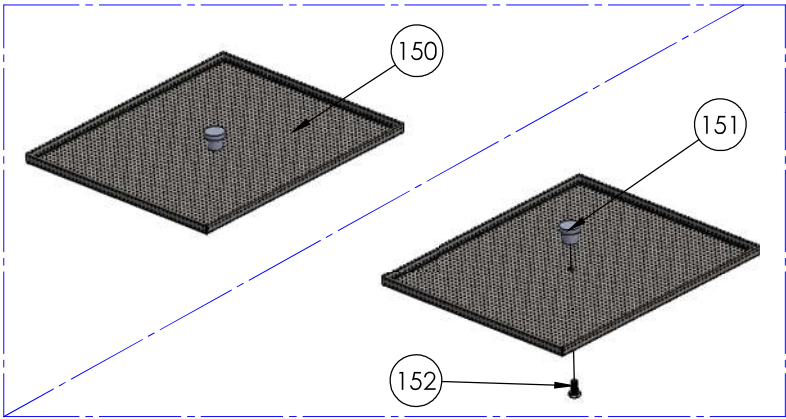

**SERIES DESCRIPTION:**  
DISHWASHER

**MODEL DESCRIPTION:**  
1510

**MODEL VERSION:**  
380V-415V 3~N 50/60 Hz

**MODEL CODE:**  
004.15.00027

**PAGE:**  
15

**REVISION:**  
01

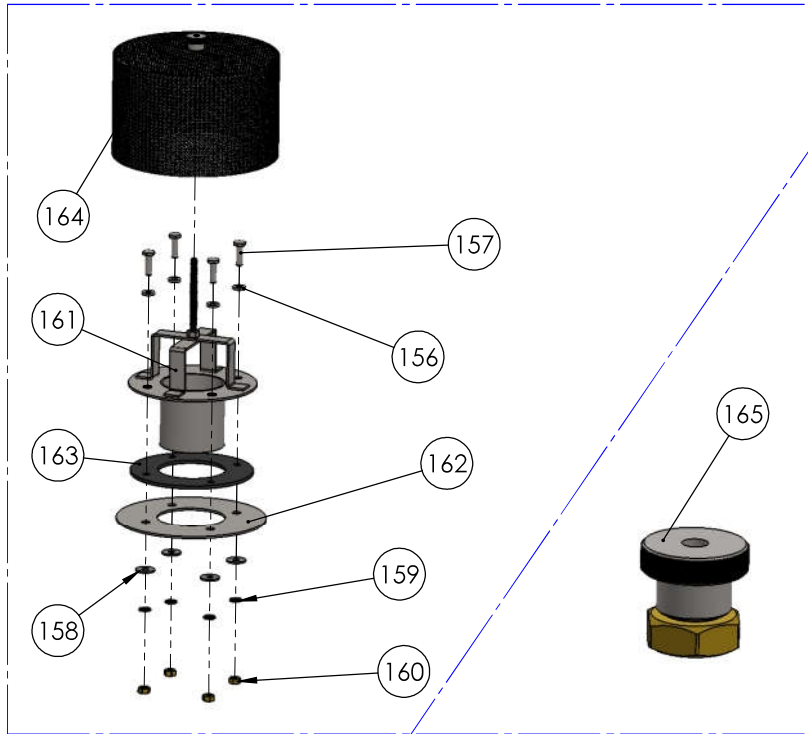

ITEM NO.	PART NUMBER	DESCRIPTION	QTY.
156	002.00.00169	TEFLON 12-6-2	4
157	003.00.00104	INOX HEX BOLT M6X20	4
158	003.00.00516	WASHER STEEL Ø6X18	4
159	001.00.00204	GALVANIZED LOCK WASHER 6,4x11x0,7	4
160	003.00.00041	NUT M6 GALVANISED	4
161	002.15.00012	BASE FOR TANK FILTER TURBO 1500	1
162	002.15.00025	RETAINING PLATE FOR FILTER 1500	1
163	002.15.00075	TANK FILTER BASE RUBBER GASKET TURBO1500	1
164	001.15.00078	PUMP FILTER TURBO 1500	1
165	001.00.00017	FILTER RETAINING NUT	1
166	003.00.00046	NUT M4 (GALV)	1
167	003.15.00095	TANK HEATING ELEMENT	1
168	002.00.00150	O-RING 45X6	1
169	003.00.00570	TANK HEATING ELEMENT RETAINING BRACKET	1
170	003.00.00004	HEATER ELEMENT COVER	1
171	003.00.00086	THREADED SHAFT M4X60	1

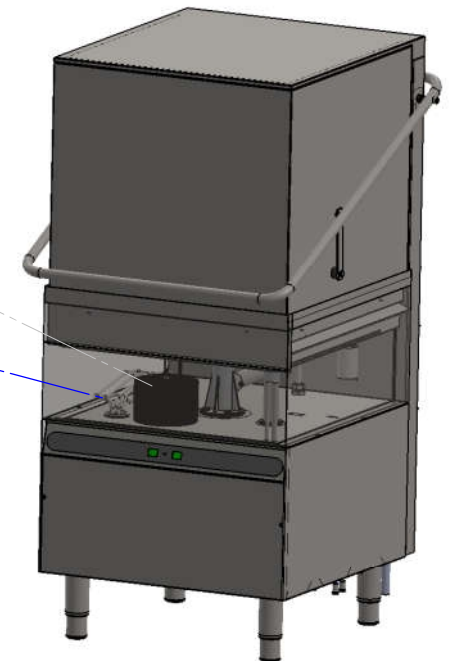
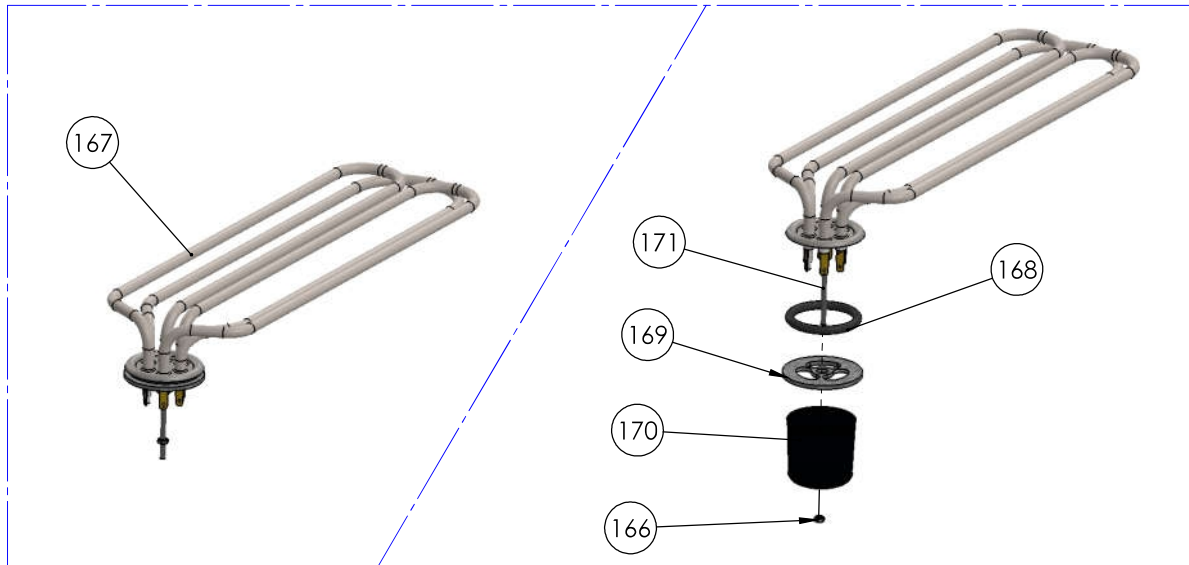

**SERIES DESCRIPTION:**  
DISHWASHER

**MODEL DESCRIPTION:**  
1510

**MODEL VERSION:**  
380V-415V 3~N 50/60 Hz

**MODEL CODE:**  
004.15.00027

**PAGE:**  
16

**REVISION:**  
01



ITEM NO.	PART NUMBER	DESCRIPTION	QTY.
172	003.00.00014	PRESSOSTAT CHAMBER	1
173	002.00.00087	NUT M10	1
174	002.00.00091	ORING 3X10,5	1
175	002.15.00031	DRAIN AND OVERFLOW PIPE	1
176	002.15.00017	DRAIN AND OVERFLOW BASE	1
177	002.00.00102-1	DRAINING BASE GASKET 1500	1
178	002.00.00037	NUT 1 1/2"	1

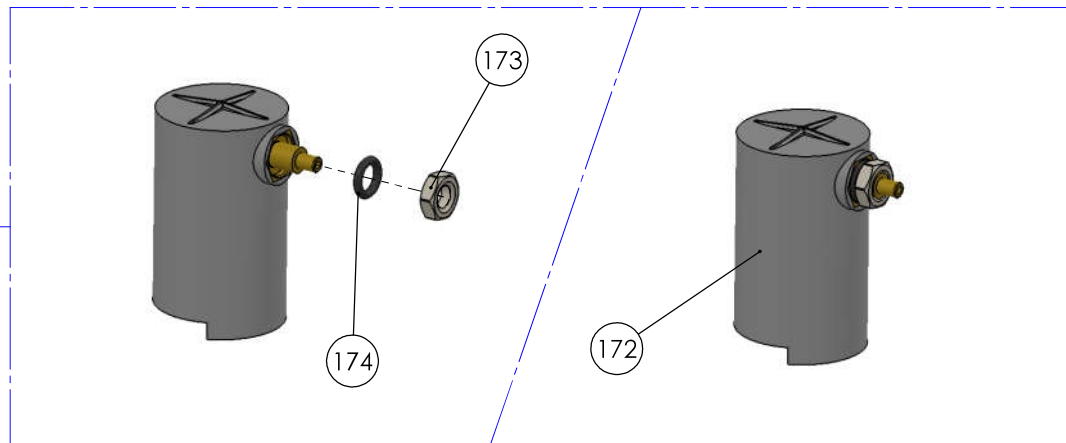
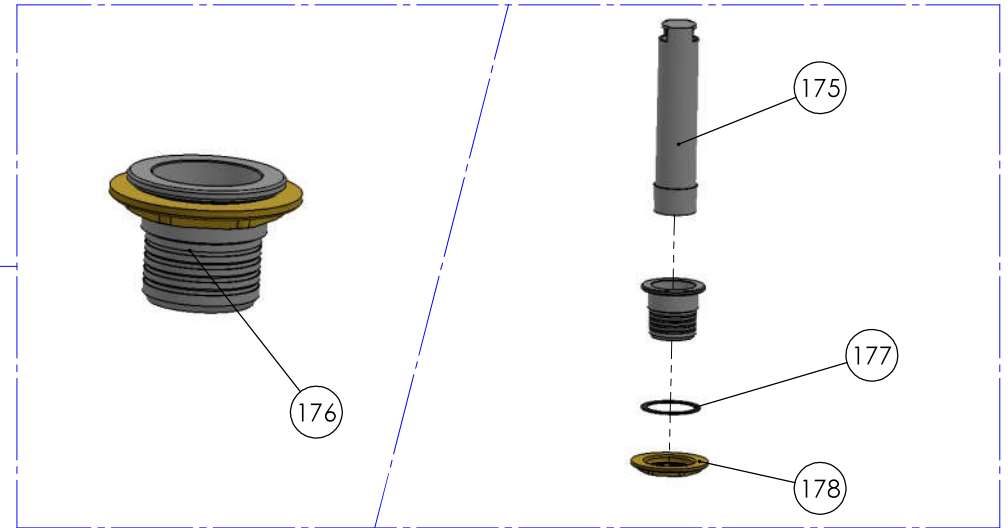
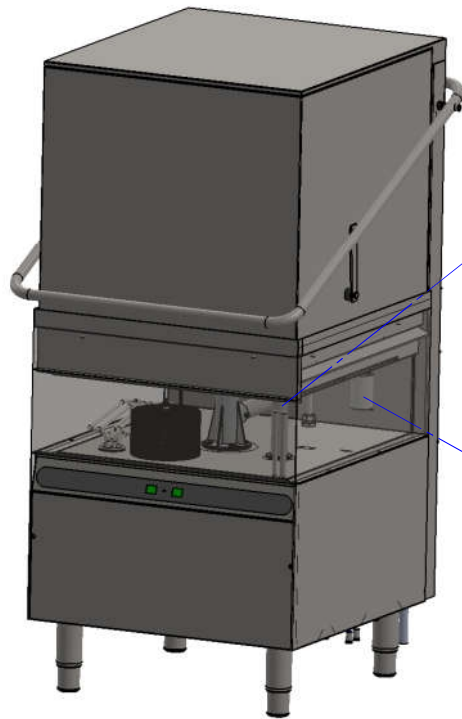

**SERIES DESCRIPTION:**  
DISHWASHER

**MODEL DESCRIPTION:**  
1510

**MODEL VERSION:**  
380V-415V 3~N 50/60 Hz

**MODEL CODE:**  
004.15.00027

**PAGE:**  
17

**REVISION:**  
01

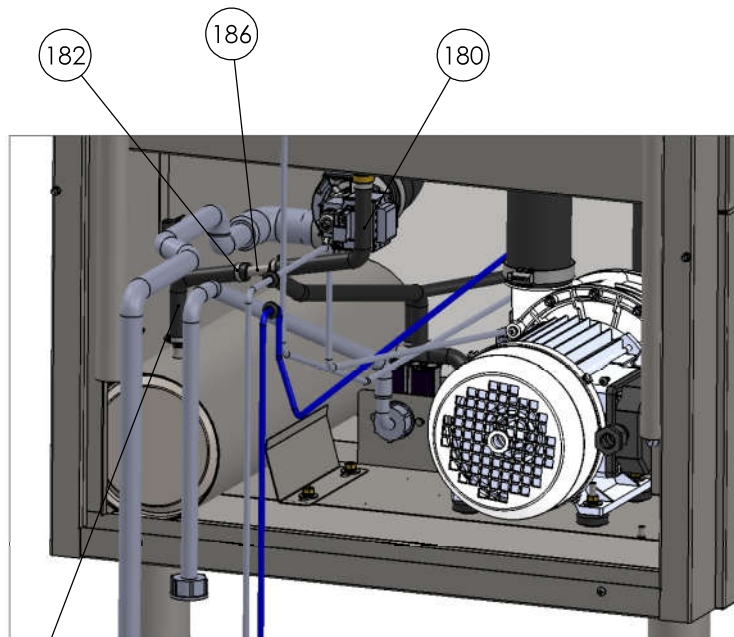

ITEM NO.	PART NUMBER	DESCRIPTION	QTY.
179	003.00.00140_13	TURBO CRISTALLO 4X6	1
180	002.00.00119-20	WASHING MACHINE HOSE BLACK 10X16.5	1
181	003.00.00140_12	TURBO CRISTALLO 4X6	1
182	002.00.00052	CLAMP 10-16	8
183	002.00.00132-4	WASHING MACHINE HOSE BLACK 6X12	1
184	002.00.00231	CLAMP 8-12	2
185	002.00.00119-23	WASHING MACHINE HOSE BLACK 10X16.5	1
186	002.51.00007	T-CONNECTION BOLIER KNOSSOS	1
187	002.00.00119-22	WASHING MACHINE HOSE BLACK 10X16.5	1

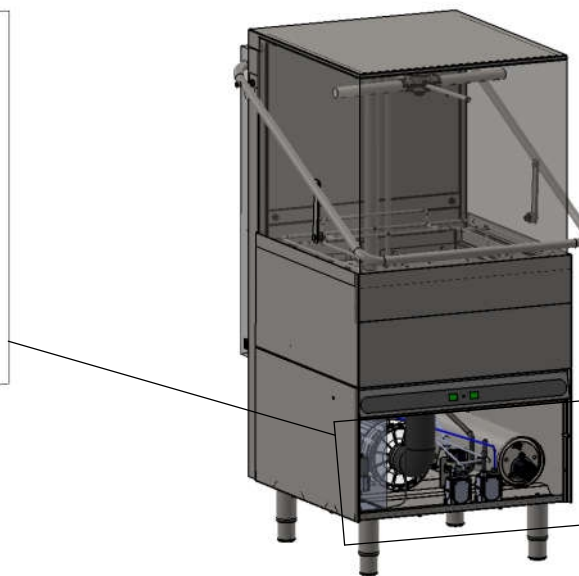
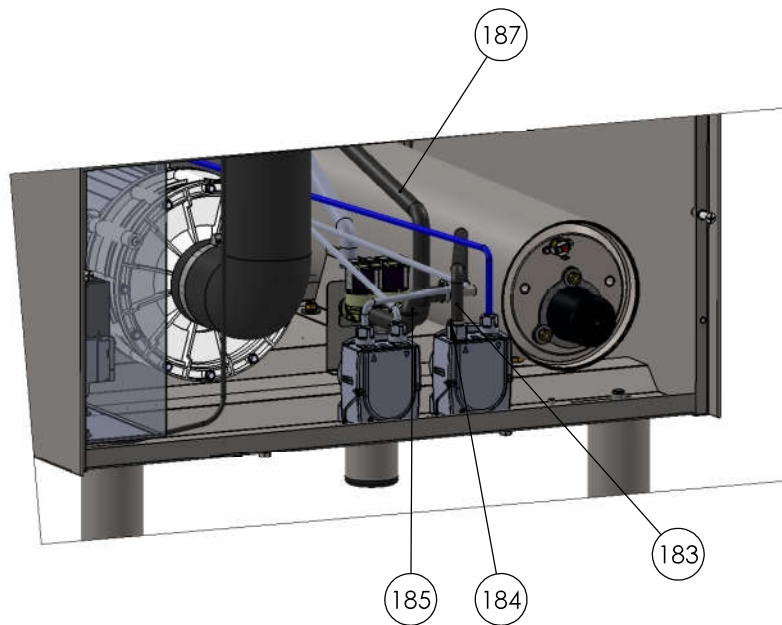
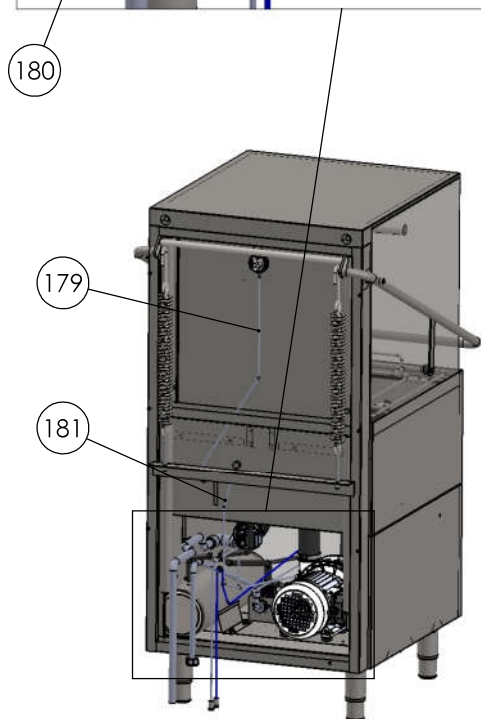

**SERIES DESCRIPTION:**  
DISHWASHER

**MODEL DESCRIPTION:**  
1510

**MODEL VERSION:**  
380V-415V 3~N 50/60 Hz

**MODEL CODE:**  
004.15.00027

**PAGE:**  
18

**REVISION:**  
01